

VIABILITA' ED ACCESSI_1:200

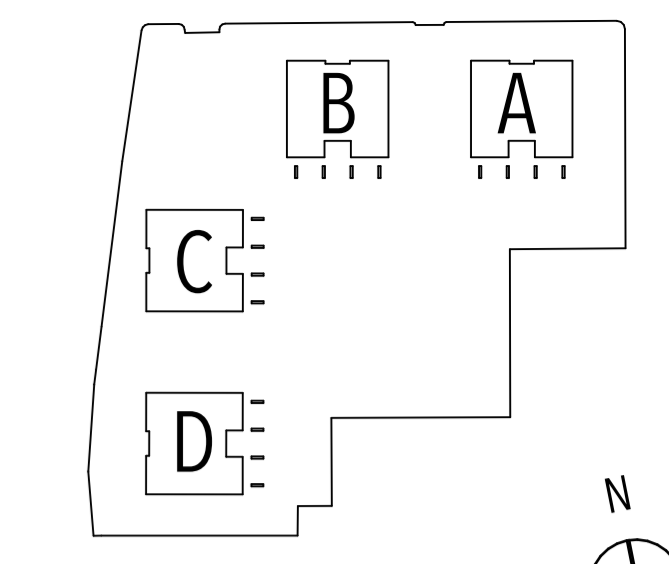

SUPERAMENTO DELLE BARRIERE ARCHITETTONICHE_1:200



KEY PLAN UNITA'
 RECINZIONE PRIVATA

COMUNE DI PADOVA



VARIANTE AL PUA DIEMME CON PRECISE DISPOSIZIONI PLANOVOLUMETRICHE

PROGETTO
L&Z ARCHITECTS
 via Noventana 192,
 35027 Noventa Padovana (PD)
 T. +39 049725181 F. +39 049725181
 studio@lez-a.it - www.lezarchitects.it
 responsabile
 Arch. Stefano Liccardo

COMMITTENTE
DUBBINI SRL
 via Battaglia 69
 35020 Albignasego (PD)
 P.IVA 02296380286

PROGETTO
DM PARK RESIDENCE
 via Caprera 31
 NCT FG 84, mapp 208
 CODICE ELABORATO

TAV.11
 TAVOLA
 PUA VARIANTE - VIABILITA', ACCESSI E SUPERAMENTO B. ARCHITETTONICHE
 DATA SCALA

NOME FILE
 Nomenclatura: PROGETTO191212_01_B_complexo_residenziale_Padova
 01_PROGETTO1212_DEFINITIVO1212_4PROGETTO1212
 Park_Progetto_PLR_var210615.pln